

LM5067

LM5067 Negative Hot Swap / Inrush Current Controller with Power Limiting



Literature Number: SNVS532B

LM5067

Negative Hot Swap / Inrush Current Controller with Power Limiting

General Description

The LM5067 negative hot swap controller provides intelligent control of the power supply connections during insertion and removal of circuit cards from a live system backplane or other "hot" power sources. The LM5067 provides in-rush current control to limit system voltage droop and transients. The current limit and power dissipation in the external series pass N-Channel MOSFET are programmable, ensuring operation within the Safe Operating Area (SOA). In addition, the LM5067 provides circuit protection by monitoring for over-current and over-voltage conditions. The POWER GOOD output indicates when the output voltage is close to the input voltage. The input under-voltage and over-voltage lockout levels and hysteresis are programmable, as well as the fault detection time. The LM5067-1 latches off after a fault detection, while the LM5067-2 automatically attempts restarts at a fixed duty cycle. The LM5067 is available in a 10 pin MSOP package and a 14 pin SOIC package.

Features

- Wide operating range: -9V to -80V
- In-rush current limit for safe board insertion into live power sources
- Programmable maximum power dissipation in the external pass device

- Adjustable current limit
- Circuit breaker function for severe over-current events
- Adjustable under-voltage lockout (UVLO) and hysteresis
- Adjustable over-voltage lockout (OVLO) and hysteresis
- Initial insertion timer allows ringing and transients to subside after system connection
- Programmable fault timer avoids nuisance trips
- Active high open drain POWER GOOD output
- Available in latched fault and automatic restart versions

Applications

- Server Backplane Systems
- In-Rush Current Limiting
- Solid State Circuit Breaker
- Transient Voltage Protector
- Solid State Relay
- Under-voltage Lock-out
- Power Good Detector/Indicator

Package

- MSOP-10
- SO-14 (Latched Fault Version)

Typical Application

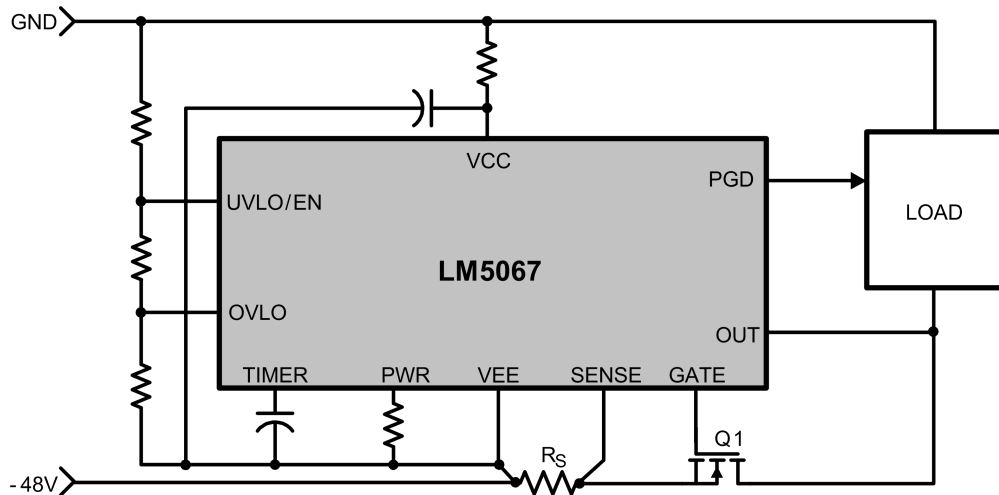

Negative Power Bus In-Rush and Fault Protection

30030901

Connection Diagrams (Note 7)

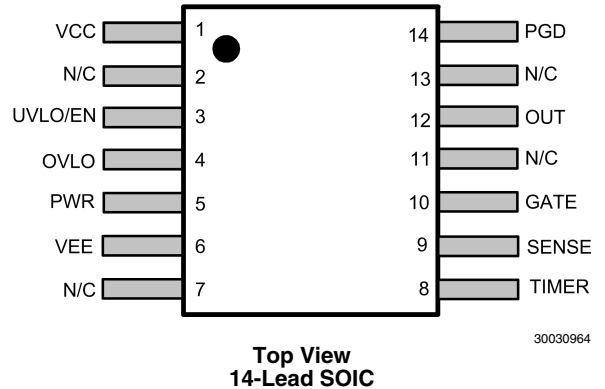
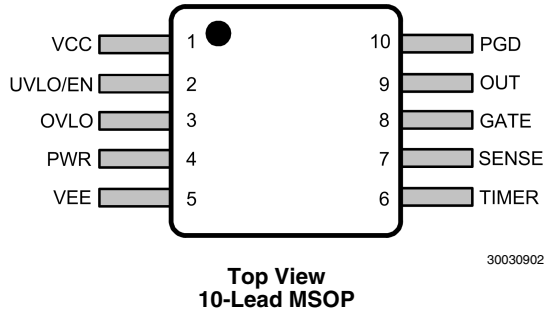

Ordering Information

Order Number	Fault Response	Package Type	NSC Package Drawing	Supplied As
LM5067MM-1	Latch Off	MSOP-10	MUB10A	1000 Units on Tape and Reel
LM5067MMX-1	Latch Off			3500 Units on Tape and Reel
LM5067MM-2	Auto Restart			1000 Units on Tape and Reel
LM5067MMX-2	Auto Restart			3500 Units on Tape and Reel
LM5067MW-1	Latch Off	SO-14	M14B	50 Units per Rail
LM5067MWX-1	Latch Off			1000 Units on Tape and Reel

Pin Descriptions

Pin #		Name	Description	Applications Information
MSOP-10	SO-14			
1	1	VCC	Positive supply input	Connect to system ground through a resistor. Connect a bypass capacitor to VEE. The voltage from VCC to VEE is nominally 13V set by an internal zener diode.
2	3	UVLO/EN	Under-voltage lockout	An external resistor divider from the system input voltage sets the under-voltage turn-on threshold. The enable threshold at the pin is 2.5V above VEE. An internal 22 μ A current source provides hysteresis. This pin can be used for remote enable and disable.
3	4	OVLO	Over-voltage lockout	An external resistor divider from the system input voltage sets the over-voltage turn-off threshold. The disable threshold at the pin is 2.5V above VEE. An internal 22 μ A current source provides hysteresis.
4	5	PWR	Power limit set	An external resistor at this pin, in conjunction with the current sense resistor (R_S), sets the maximum power dissipation in the external series pass MOSFET.
5	6	VEE	Negative supply input	Connect to the system negative supply voltage (typically -48V).
6	8	TIMER	Timing capacitor	An external capacitor at this pin sets the insertion time delay and the fault timeout period. The capacitor also sets the restart timing of the LM5067-2.
7	9	SENSE	Current sense input	The voltage across the current sense resistor (R_S) is measured from VEE to this pin. If the voltage across R_S reaches 50 mV the load current is limited and the fault timer activates.
8	10	GATE	Gate drive output	Connect to the external N-channel MOSFET's gate.

Pin #		Name	Description	Applications Information
MSOP-10	SO-14			
9	12	OUT	Output feedback	Connect to the external MOSFET's drain. Internally used to determine the MOSFET V_{DS} voltage for power limiting, and to control the PGD output pin.
10	14	PGD	Power Good indicator	An open drain output capable of sustaining 80V when off. When the external MOSFET V_{DS} decreases below 1.23V the PGD pin switches high. When the external MOSFET V_{DS} increases above $\approx 2.5V$ the PGD pin switches low.

Absolute Maximum Ratings *(Note 1)*

If Military/Aerospace specified devices are required, please contact the National Semiconductor Sales Office/ Distributors for availability and specifications.

Current into VCC (100 μ s pulse)	100 mA
OUT, PGD to VEE	-0.3V to 100V
UVLO, OVLO to VEE	-0.3V to 17V
SENSE to VEE	-0.3V to +0.3V
ESD Rating <i>(Note 2)</i>	2kV
Human Body Model	

Storage Temperature	-65°C to +150°C
Junction Temperature	+150°C

Operating Ratings

Current into VCC <i>(Note 5)</i>	2 mA (min)
OUT Voltage above VEE	0V to 80V
PGD Off Voltage above VEE	0V to 80V
Junction Temperature	-40°C to +125°C

Electrical Characteristics Limits in standard type are for $T_J = 25^\circ\text{C}$ only; limits in boldface type apply over the junction temperature (T_J) range of -40°C to $+125^\circ\text{C}$. Minimum and Maximum limits are guaranteed through test, design, or statistical correlation. Typical values represent the most likely parametric norm at $T_J = 25^\circ\text{C}$, and are provided for reference purposes only. Unless otherwise stated the following conditions apply: $I_{CC} = 2$ mA, OUT Pin = 48V above VEE, all voltages are with respect to VEE. See *(Note 3)*.

Symbol	Parameter	Conditions	Min	Typ	Max	Units
Input						
V_Z	Operating voltage, VCC – VEE	$I_{CC} = 2$ mA, UVLO = 5V	12.35	13	13.65	V
I_{CC-EN}	Internal operating current, enabled	VCC-VEE = 11V, UVLO = 5V		0.8	1	mA
I_{CC-DIS}	Internal operating current, disabled	VCC-VEE = 11V, UVLO = 2V		480	660	μ A
POR_{IT}	Threshold voltage to start insertion timer	VCC-VEE increasing		7.7	8.2	V
POR_{EN}	Threshold voltage to enable all functions	VCC-VEE increasing		8.4	8.7	V
POR_{EN-HYS}	POR_{EN} hysteresis	VCC-VEE decreasing		125		mV
OUT Pin						
I_{OUT-EN}	OUT bias current, enabled	OUT = VEE, Normal operation		0.1		μ A
$I_{OUT-DIS}$	OUT bias current, disabled	Disabled, OUT = VEE + 48V		50		
SENSE Pin						
I_{SNS-EN}	SENSE bias current, enabled	OUT = VEE, Normal operation		-6		μ A
$I_{SNS-DIS}$	SENSE bias current, disabled	Disabled, OUT = VEE + 48V		-50		
UVLO, OVLO Pins						
$UVLO_{TH}$	UVLO threshold		2.45	2.5	2.55	V
$UVLO_{HYS}$	UVLO hysteresis current	UVLO = VEE + 2V	10	22	34	μ A
$UVLO_{DEL}$	UVLO delay	Delay to GATE high		26		μ s
		Delay to GATE low		12		μ s
$UVLO_{BIAS}$	UVLO bias current	UVLO = VEE + 5V			1	μ A
$OVLO_{TH}$	OVLO threshold		2.43	2.5	2.57	V
$OVLO_{HYS}$	OVLO hysteresis current	OVLO = VEE+2.8V	-34	-22	-10	μ A
$OVLO_{DEL}$	OVLO delay	Delay to GATE high		26		μ s
		Delay to GATE low		12		μ s
$OVLO_{BIAS}$	OVLO bias current	OVLO = VEE + 2.4V			1	μ A
Gate Control (GATE Pin)						
I_{GATE}	Source current	Normal Operation	-72	-52	-32	μ A
	Sink current	UVLO < 2.5V	1.9	2.2	2.68	mA
		SENSE - VEE =150 mV or VCC - VEE < POR_{IT} , $V_{GATE} = 5V$	45	110	200	
V_{GATE}	Gate output voltage in normal operation	GATE-VEE voltage		V_Z		V

Symbol	Parameter	Conditions	Min	Typ	Max	Units
Current Limit						
V_{CL}	Threshold voltage	SENSE - VEE voltage	44	50	56	mV
t_{CL}	Response time	SENSE - VEE stepped from 0 mV to 80 mV		25		μ s
Circuit Breaker						
V_{CB}	Threshold voltage	SENSE - VEE voltage	70	100	130	mV
t_{CB}	Response time	SENSE - VEE stepped from 0 mV to 150 mV, time to GATE low, no load		0.65	1.0	μ s
Power Limit (PWR Pin)						
PWR_{LIM}	Power limit sense voltage (SENSE - VEE)	OUT - SENSE = 24V, $R_{PWR} = 75$ k Ω	16.5	22	27.5	mV
I_{PWR}	PWR pin current	$V_{PWR} = 2.5V$		-23		μ A
Timer (TIMER Pin)						
V_{TMRH}	Upper threshold		3.76	4	4.16	V
V_{TMRL}	Lower threshold	Restart cycles (LM5067-2)	1.18	1.25	1.32	V
		End of 8th cycle (LM5067-2)		0.3		V
		Re-enable threshold (LM5067-1)		0.3		V
I_{TIMER}	Insertion time current	TIMER pin = 2V	-9.5	-6	-2.5	μ A
	Sink current, end of insertion time	TIMER pin = 2V	1.2	1.55	1.9	mA
	Fault detection current	TIMER pin = 2V	-140	-85	-44	μ A
	Sink current, end of fault time		0.9	2.5	4.25	μ A
DC_{FAULT}	Fault Restart Duty Cycle	LM5067-2		0.5		%
t_{FAULT}	Fault to GATE low delay	TIMER pin reaches 4.0V		15		μ s
Power Good (PGD Pin)						
PGD_{TH}	Threshold measured at OUT - SENSE	Decreasing	1.162	1.23	1.285	V
		Increasing, relative to decreasing threshold	1.143	1.25	1.325	
PGD_{VOL}	Output low voltage	$I_{SINK} = 2$ mA		60	150	mV
PGD_{IOH}	Off leakage current	$V_{PGD} = 80V$			5	μ A
Thermal Resistance (Note 6)						
θ_{JA}	Junction to Ambient	MSOP package		94		$^{\circ}C/W$
θ_{JC}	Junction to Case	MSOP package		44		$^{\circ}C/W$
θ_{JA}	Junction to Ambient	SO-14 Package		90		$^{\circ}C/W$
θ_{JC}	Junction to Case	SO-14 Package		27		$^{\circ}C/W$

Note 1: Absolute Maximum Ratings indicate limits beyond which damage to the device may occur. Operating Ratings indicate conditions for which the device is intended to be functional, but do not guarantee specific performance limits. For guaranteed specifications and conditions see the Electrical Characteristics.

Note 2: The human body model is a 100 pF capacitor discharged through a 1.5 k Ω resistor into each pin.

Note 3: Current out of a pin is indicated as a negative value.

Note 4: For detailed information on soldering plastic MSOP package refer to the Packaging Databook available from National Semiconductor Corporation.

Note 5: Maximum continuous current into VCC is limited by power dissipation and die temperature. See the Thermal Considerations section.

Note 6: Tested on a 4 layer JEDEC board with 2 vias under the package. See JEDEC standards JESD51-7 and JESD51-3. See the Thermal Considerations section.

Note 7: N/C Pins are internally not connected to anything.

Typical Performance Characteristics

Unless otherwise specified the following conditions

apply: $T_J = 25^\circ\text{C}$.

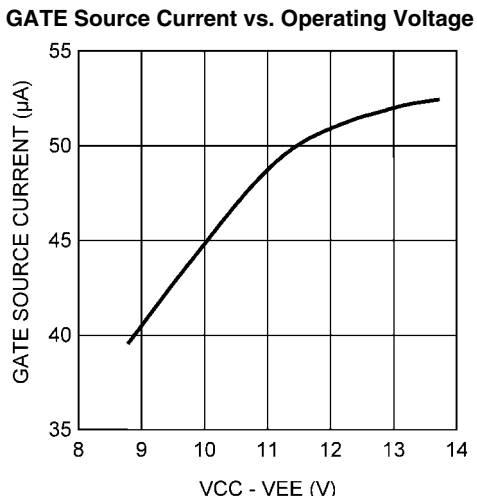
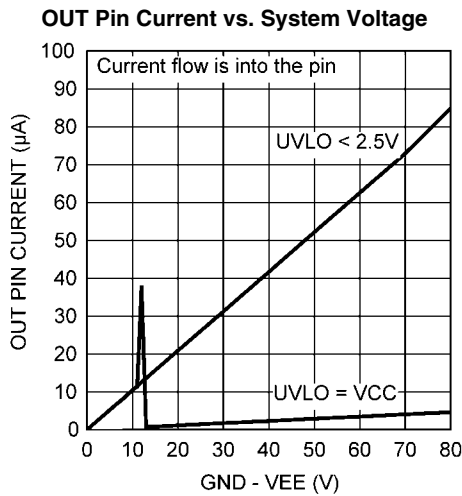
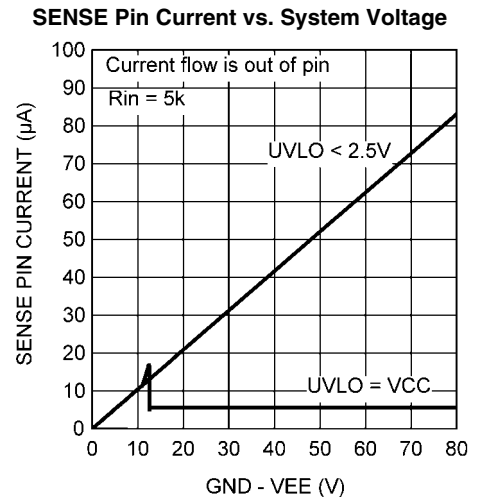
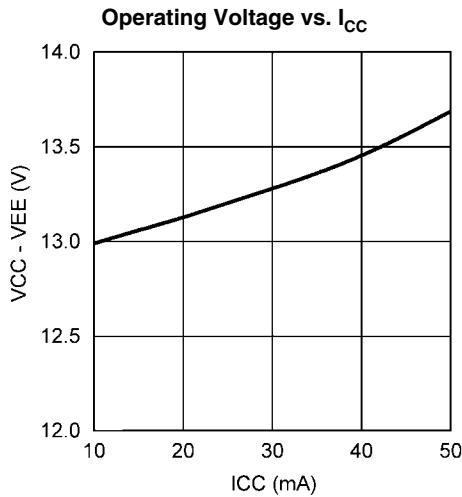
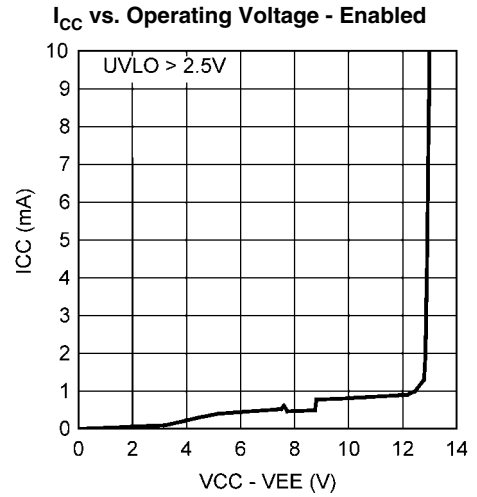
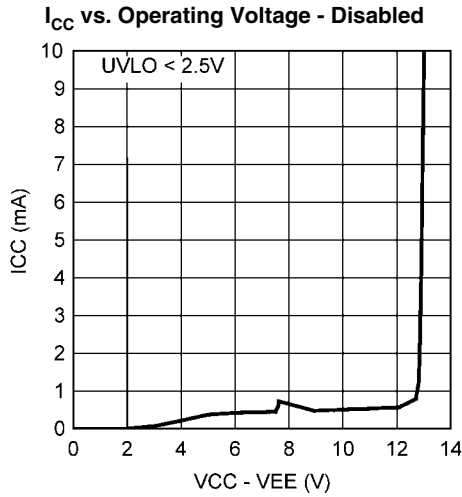

GATE Pull-Down Current, Circuit Breaker vs. GATE Voltage

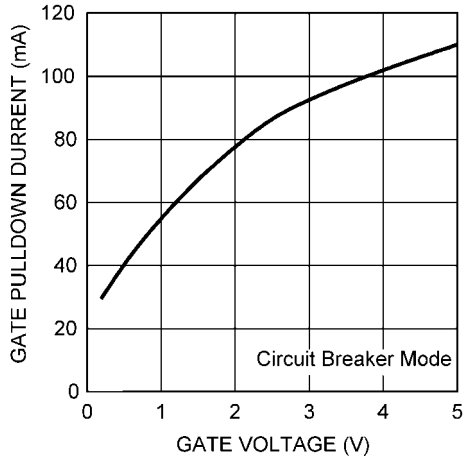

30030910

PGD Low Voltage vs. Sink Current

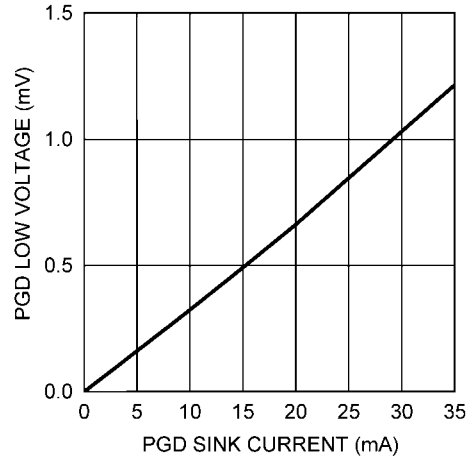

30030911

MOSFET Power Dissipation Limit vs. R_{PWR} and R_S

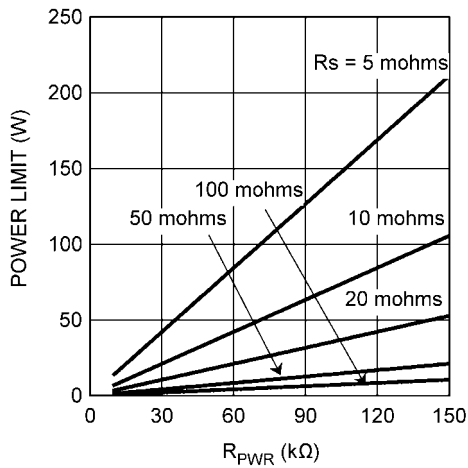

30030912

UVLO & OVLO Hysteresis Current vs. Temperature

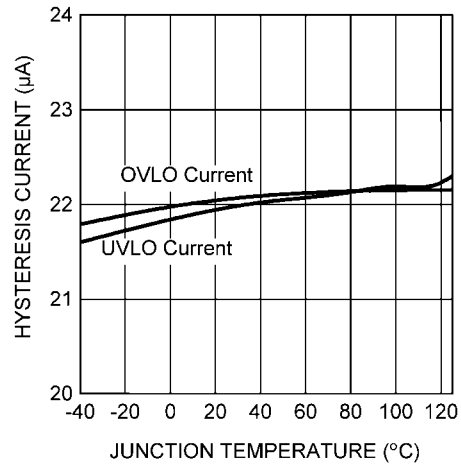

30030913

UVLO, OVLO Threshold Voltage vs. Temperature

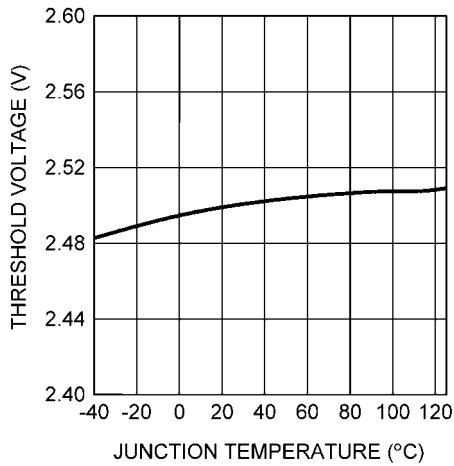

30030915

V_Z Operating Voltage vs. Temperature

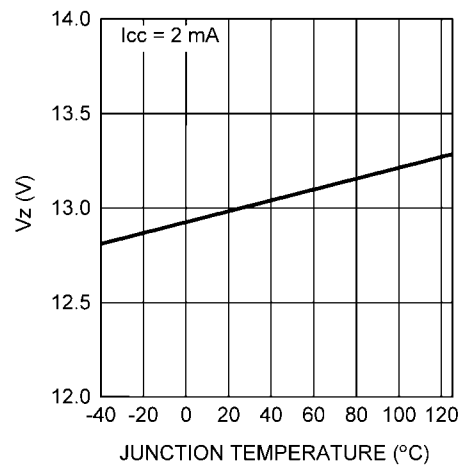

30030916

Current Limit Threshold vs. Temperature

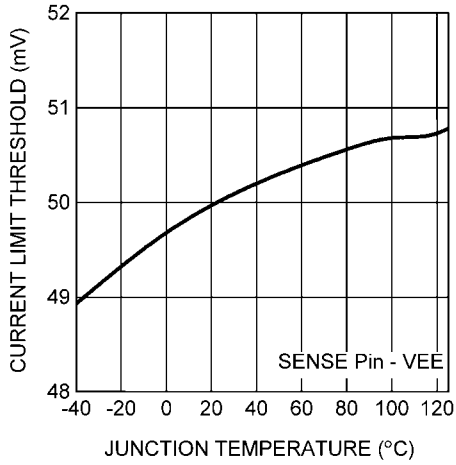

30030917

Circuit Breaker Threshold vs. Temperature

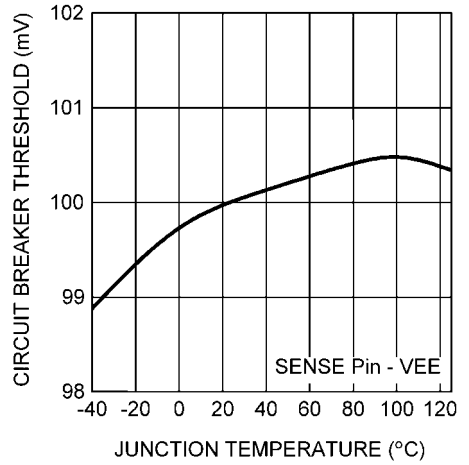

30030918

Power Limit Threshold vs. Temperature

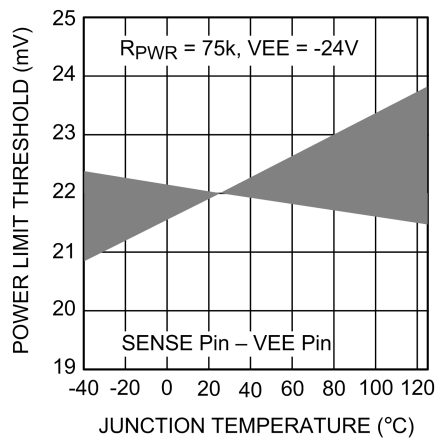

30030919

Gate Source Current vs. Temperature

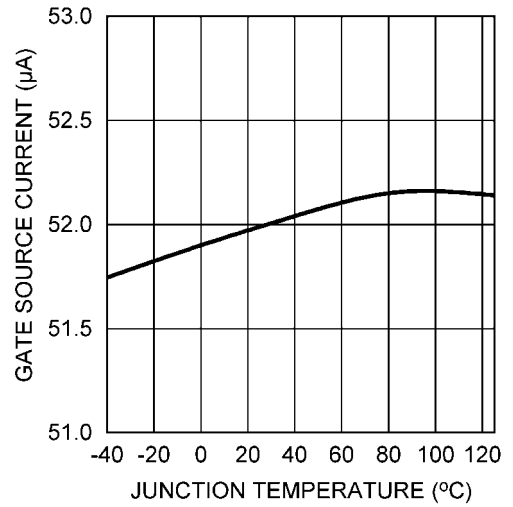

30030920

GATE Pull-Down Current, Circuit Breaker vs. Temperature

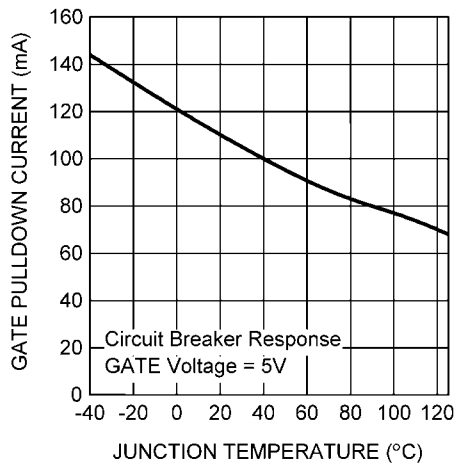

30030921

PGD Pin Low Voltage vs. Temperature

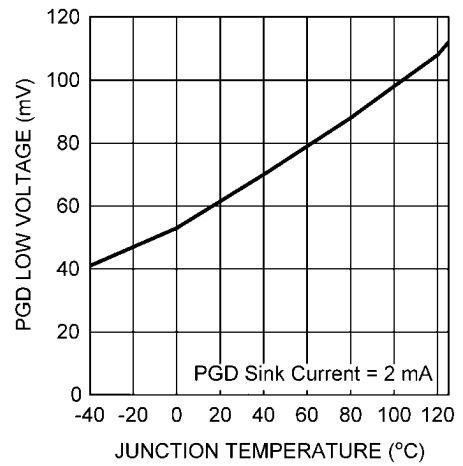

30030922

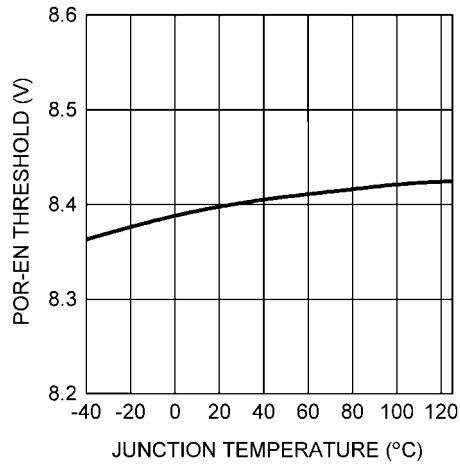
POR_{EN} Threshold vs. Temperature

30030923

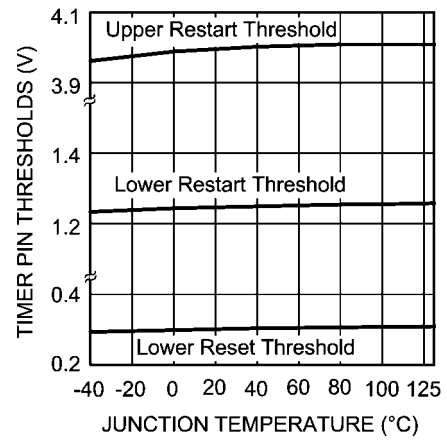
TIMER Pin Thresholds vs. Temperature

30030925

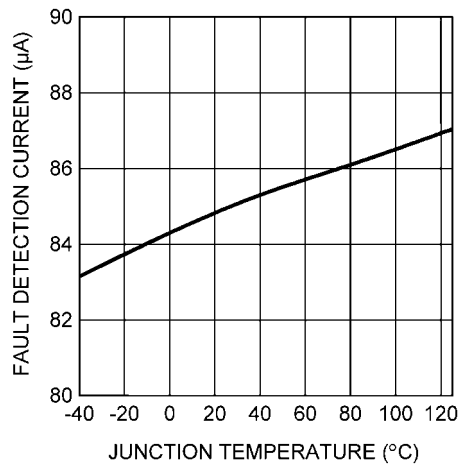
TIMER Pin Fault Detection Current vs. Temperature

30030926

Block Diagram

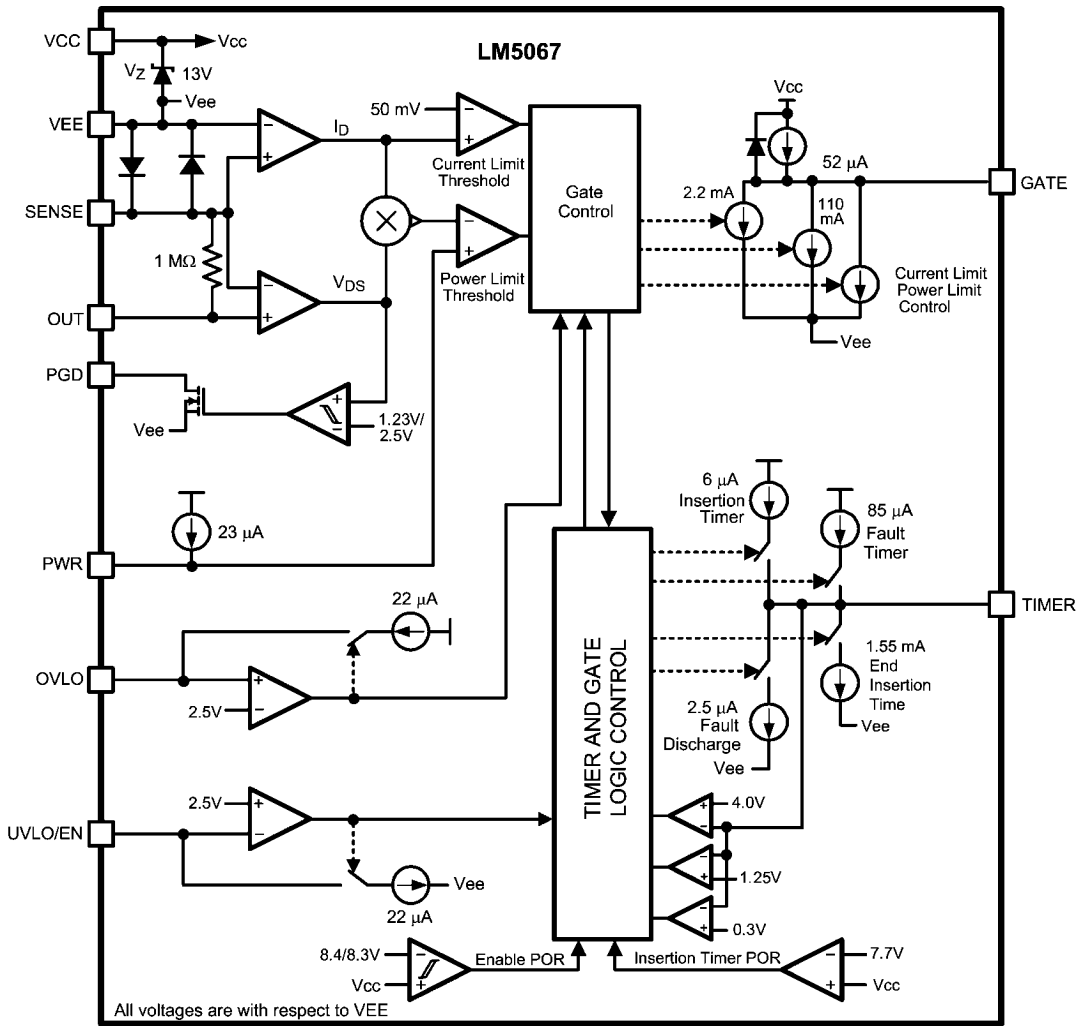

30030927

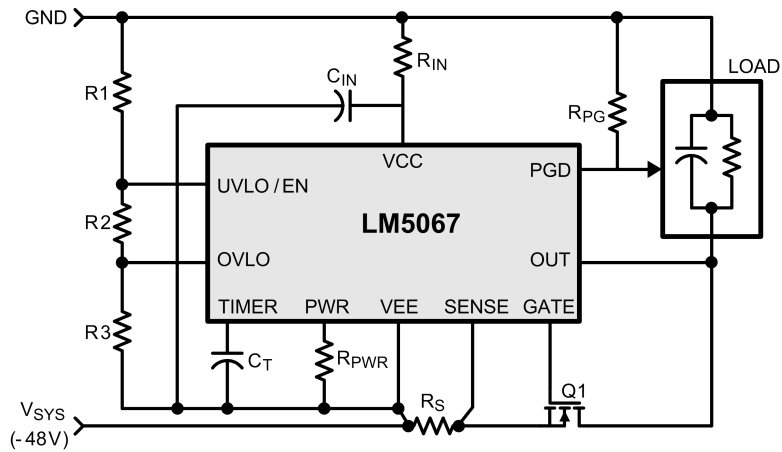

30030928

FIGURE 1. Basic Application Circuit

Functional Description

The LM5067 is designed to control the in-rush current to the load upon insertion of a circuit card into a live backplane or other “hot” power source, thereby limiting the voltage sag on the backplane’s supply voltage, and the dV/dt of the voltage applied to the load. Effects on other circuits in the system are minimized, preventing possible unintended resets. During the system power up, the maximum power dissipation in the series pass device is limited to a safe value within the device’s Safe Operating Area (SOA). After the system power up is complete, the LM5067 monitors the load for excessive currents due to a fault or short circuit at the load. Limiting the load current and/or the power in the external MOSFET for an ex-

tended period of time results in the shutdown of the series pass MOSFET. After a fault event, the LM5067-1 latches off until the circuit is re-enabled by external control, while the LM5067-2 automatically restarts with defined timing. The circuit breaker function quickly switches off the series pass device upon detection of a severe over-current condition caused by, e.g. a short circuit at the load. The Power Good (PGD) output pin indicates when the output voltage is close to the normal operating value. Programmable under-voltage lock-out (UVLO) and over-voltage lock-out (OVLO) circuits shut down the LM5067 when the system input voltage is outside the desired operating range. The typical configuration of a circuit card with LM5067 hot swap protection is shown in Figure 2.

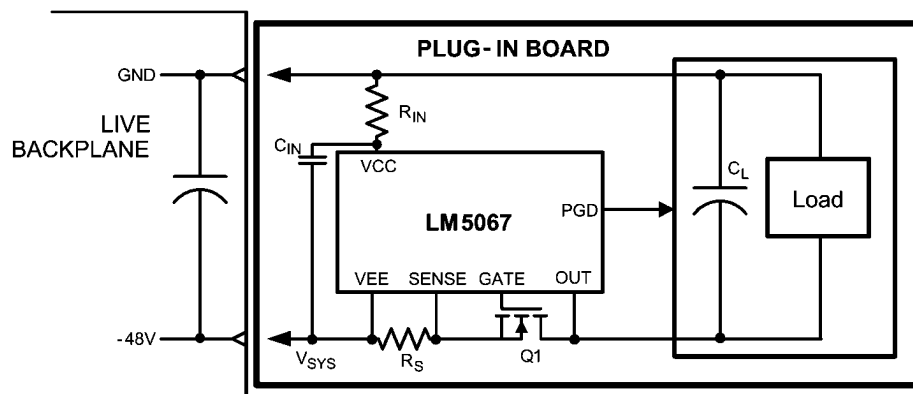

30030929

FIGURE 2. LM5067 Application

The LM5067 can be used in a variety of applications, other than plug-in boards, to monitor for excessive load current, provide transient protection, and ensuring the voltage to the load is within preferred limits. The circuit breaker function protects the system from a sudden short circuit at the load. Use of the UVLO/EN pin allows the LM5067 to be used as a solid state relay. The PGD output provides a status indication of the voltage at the load relative to the input system voltage.

Power Up Sequence

The system voltage range of the LM5067 is -9V to -80V, with a transient capability to -100V. Referring to the Block Diagram and Figures 1 and 3, as the system voltage (V_{SYS}) initially increases from zero, the external N-channel MOSFET (Q1) is held off by an internal 110 mA pull-down current at the GATE pin. The strong pull-down current at the GATE pin prevents an inadvertent turn-on as the MOSFET’s gate-to-drain (Miller) capacitance is charged. When the operating voltage of the LM5067 ($V_{CC} - V_{EE}$) reaches the POR_{IT} threshold (7.7V) the insertion timer starts. During the insertion time, the capacitor at the TIMER pin (C_T) is charged by a 6 μ A current source, and Q1 is held off by a 2.2 mA pull-down current at the GATE pin regardless of the system voltage. The insertion time delay allows ringing and transients at V_{SYS} to settle before Q1 can be enabled. The insertion time ends when the TIMER pin voltage reaches 4.0V above VEE, and C_T is then quickly discharged by an internal 1.5 mA pull-down current. After the insertion time, the LM5067 control circuitry is enabled when

the operating voltage reaches the POR_{EN} threshold (8.4V). As V_{SYS} continues to increase, the LM5067 operating voltage is limited at $\approx 13V$ by an internal zener diode. The remainder of the system voltage is dropped across the input resistor R_{IN} .

The GATE pin switches on Q1 when V_{SYS} exceeds the UVLO threshold (UVLO pin $>2.5V$ above VEE). If V_{SYS} exceeds the UVLO threshold at the end of the insertion time, Q1 is switched on at that time. The GATE pin sources 52 μ A to charge Q1’s gate capacitance. The maximum gate-to-source voltage of Q1 is limited by the LM5067’s operating voltage (V_Z) to approximately 13V. During power up, as the voltage at the OUT pin increases in magnitude with respect to Ground, the LM5067 monitors Q1’s drain current and power dissipation. In-rush current limiting and/or power limiting circuits actively control the current delivered to the load. During the in-rush limiting interval (t_2 in Figure 3) an internal current source charges C_T at the TIMER pin. When the load current reduces from the limiting value to a value determined by the load the in-rush limiting interval is complete and C_T is discharged. The PGD pin switches high when the voltage at the OUT pin reaches to within 1.25V of the voltage at the SENSE pin.

If the TIMER pin voltage reaches 4.0V before in-rush current limiting or power limiting ceases (during t_2), a fault is declared and Q1 is turned off. See the Fault Timer & Restart section for a complete description of the fault mode.

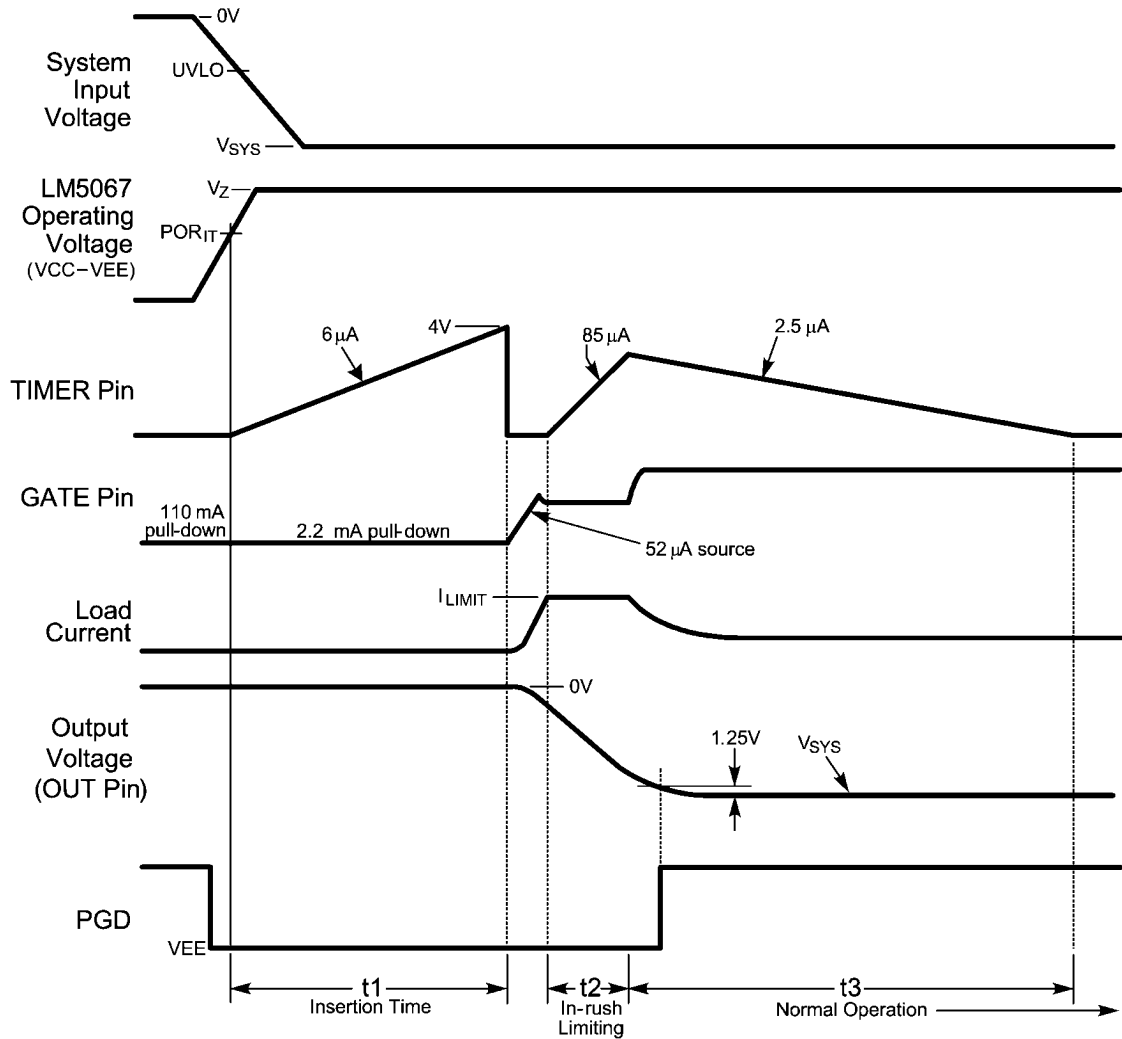

All waveforms and voltages are with respect to VEE except System Input Voltage and Output Voltage

30030930

FIGURE 3. Power Up Sequence (Current Limit only)

Operating Voltage

The LM5067 operating voltage is the voltage from VCC to VEE. The maximum operating voltage is set by an internal 13V zener diode. With the IC connected as shown in Figure 1, the LM5067 controller operates in the voltage range between VEE and VEE+13V. The remainder of the system voltage is dropped across the input resistor R_{IN} , which must be selected to pass at least 2 mA into the LM5067 at the minimum system voltage.

Gate Control

The external N-channel MOSFET is turned on when the GATE pin sources 52 μ A to enhance the gate. During normal operation (t3 in Figure 3) Q1's gate is held charged to approximately 13V above VEE, typically within 20 mV of the voltage at VCC. If the maximum V_{GS} rating of Q1 is less than 13V, a lower voltage external zener diode must be added between the GATE and SENSE pins. The external zener diode must have a forward current rating of at least 110 mA.

When the system voltage is initially applied (before the operating voltage reaches the POR_{IT} threshold), the GATE pin is held low by a 110 mA pull-down current. The pull-down current helps prevent an inadvertent turn-on of the MOSFET through its drain-gate capacitance as the applied system voltage increases.

During the insertion time (t1 in Figure 3) the GATE pin is held low by a 2.2 mA pull-down current. This maintains Q1 in the off-state until the end of t1, regardless of the voltage at VCC and UVLO.

Following the insertion time, during t2 in Figure 3, the gate voltage of Q1 is modulated to keep the current or Q1's power dissipation level from exceeding the programmed levels. Current limiting and power limiting are considered fault conditions, during which the voltage on the TIMER pin capacitor increases. If the current and power limiting cease before the TIMER pin reaches 4V the TIMER pin capacitor is discharged, and the circuit enters normal operation. See the Fault Timer & Restart paragraph for details on the fault timer.

If the system input voltage falls below the UVLO threshold, or rises above the OVLO threshold, the GATE pin is pulled low by the 2.2 mA pull-down current to switch off Q1.

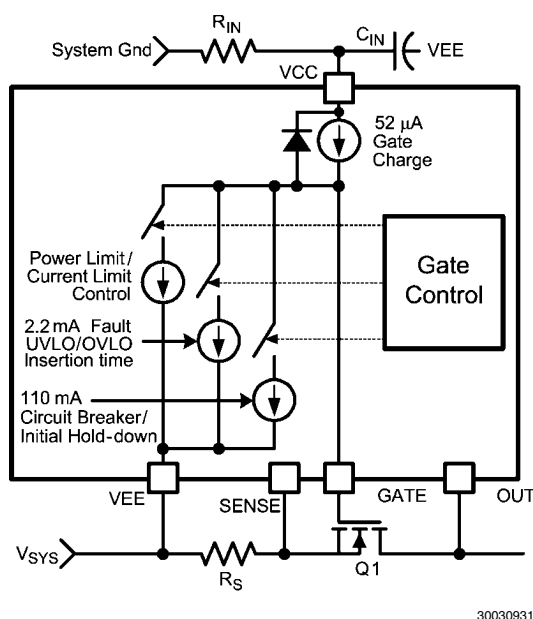

FIGURE 4. Gate Control

Current Limit

The current limit threshold is reached when the voltage across the sense resistor R_S (SENSE to VEE) reaches 50 mV. In the current limiting condition, the GATE voltage is controlled to limit the current in MOSFET Q1. While the current limit circuit is active, the fault timer is active as described in the Fault Timer & Restart section. If the load current reduces below the current limit threshold before the end of the Fault Timeout Period, the LM5067 resumes normal operation. For proper operation, the R_S resistor value should be no larger than 100 m Ω .

Circuit Breaker

If the load current increases rapidly (e.g., the load is short-circuited) the current in the sense resistor (R_S) may exceed the current limit threshold before the current limit control loop is able to respond. If the current exceeds approximately twice the current limit threshold ($100 \text{ mV}/R_S$), Q1's gate is quickly pulled down by the 110 mA pull-down current at the GATE pin, and a Fault Timeout Period begins. When the voltage across R_S falls below 100 mV the 110 mA pull-down current at the GATE pin is switched off, and the gate voltage of Q1 is then determined by the current limit or the power limit functions. If the TIMER pin reaches 4.0V before the current limiting or power limiting condition ceases, Q1 is switched off by the 2.2 mA pull-down current at the GATE pin as described in the Fault Timer & Restart section.

Power Limit

An important feature of the LM5067 is the MOSFET power limiting. The Power Limit function can be used to maintain the

maximum power dissipation of MOSFET Q1 within the device SOA rating. The LM5067 determines the power dissipation in Q1 by monitoring its drain-source voltage (OUT to SENSE), and the drain current through the sense resistor (SENSE to VEE). The product of the current and voltage is compared to the power limit threshold programmed by the resistor at the PWR pin. If the power dissipation reaches the limiting threshold, the GATE voltage is modulated to reduce the current in Q1, and the fault timer is active as described in the Fault Timer & Restart section.

Fault Timer & Restart

When the current limit or power limit threshold is reached during turn-on or as a result of a fault condition, the gate-to-source voltage of Q1 is modulated to regulate the load current and power dissipation in Q1. When either limiting function is active, an 85 μA fault timer current source charges the external capacitor (C_T) at the TIMER pin as shown in Figure 6 (Fault Timeout Period). If the fault condition subsides before the TIMER pin reaches 4.0V, the LM5067 returns to the normal operating mode and C_T is discharged by the 2.5 μA current sink. If the TIMER pin reaches 4.0V during the Fault Timeout Period, Q1 is switched off by a 2.2 mA pull-down current at the GATE pin. The subsequent restart procedure depends on which version of the LM5067 is in use.

The LM5067-1 latches the GATE pin low at the end of the Fault Timeout Period, and C_T is discharged by the 2.5 μA fault current sink. The GATE pin is held low until a power up sequence is externally initiated by cycling the input voltage (V_{SYS}), or momentarily pulling the UVLO/EN pin within 2.5V of VEE with an open-collector or open-drain device as shown in Figure 5. The voltage across C_T must be <0.3V for the restart procedure to be effective.

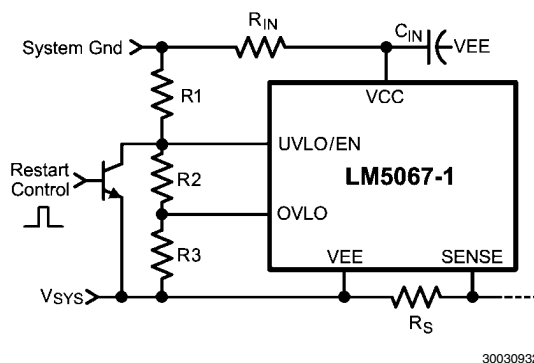
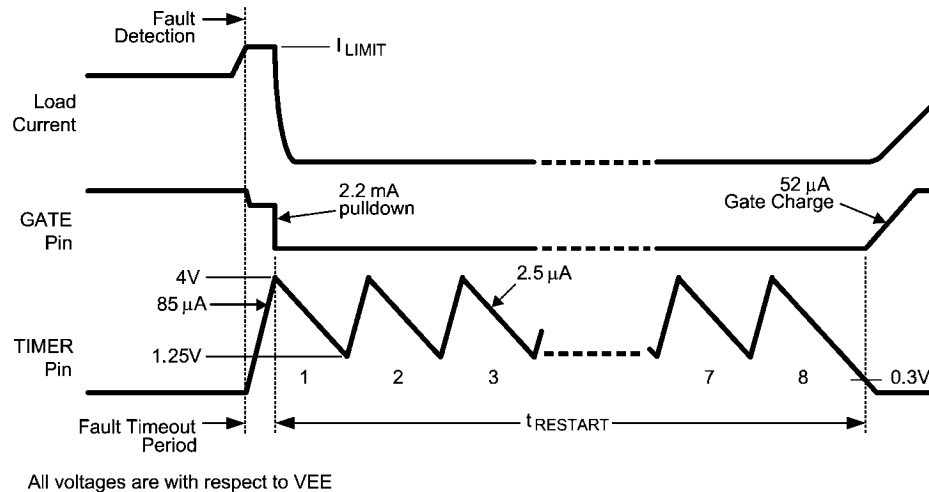

FIGURE 5. Latched Fault Restart Control

The LM5067-2 provides an automatic restart sequence which consists of the TIMER pin cycling between 4.0V and 1.25V seven times after the Fault Timeout Period, as shown in Figure 6. The period of each cycle is determined by the 85 μA charging current, and the 2.5 μA discharge current, and the value of the capacitor C_T . When the TIMER pin reaches 0.3V during the eighth high-to-low ramp, the 52 μA current source at the GATE pin turns on Q1. If the fault condition is still present, the Fault Timeout Period and the restart cycle repeat.



30030933

FIGURE 6. Restart Sequence (LM5067-2)

Under-Voltage Lock-Out (UVLO)

The series pass MOSFET (Q1) is enabled when the input supply voltage (V_{SYS}) is within the operating range defined by the programmable under-voltage lockout (UVLO) and over-voltage lock-out (OVLO) levels. Typically the UVLO level at V_{SYS} is set with a resistor divider (R1-R3) as shown in Figure 1. When V_{SYS} is less than the UVLO level, the internal 22 μA current sink at UVLO/EN is enabled, the current source at OVLO is off, and Q1 is held off by the 2.2 mA pull-down current at the GATE pin. V_{SYS} reaches its UVLO level when the voltage at the UVLO/EN pin reaches 2.5V above VEE. Upon reaching the UVLO level, the 22 μA current sink at the UVLO/EN pin is switched off, increasing the voltage at the pin, providing hysteresis for this threshold. With the UVLO/EN pin above 2.5V, Q1 is switched on by the 52 μA current source at the GATE pin.

See the Applications Section for a procedure to calculate the values of the threshold setting resistors (R1-R3). The minimum possible UVLO level can be set by connecting the UVLO/EN pin to VCC. In this case Q1 is enabled when the operating voltage ($V_{CC} - V_{EE}$) reaches the POR_{EN} threshold (8.4V).

Over-Voltage Lock-Out (OVLO)

The series pass MOSFET (Q1) is enabled when the input supply voltage (V_{SYS}) is within the operating range defined by the programmable under-voltage lockout (UVLO) and over-voltage lock-out (OVLO) levels. Typically the OVLO level at V_{SYS} is set with a resistor divider (R1-R3) as shown in Figure 1. If V_{SYS} raises the OVLO pin voltage more than 2.5V above VEE Q1 is switched off by the 2.2 mA pull-down current at the GATE pin, denying power to the load. When the OVLO pin is above 2.5V, the internal 22 μA current source at OVLO is switched on, raising the voltage at OVLO and providing threshold hysteresis. When the voltage at the OVLO pin is reduced below 2.5V the 22 μA current source is switched off, and Q1 is enabled. See the Applications Section for a procedure to calculate the threshold setting resistor values.

Shutdown/Enable Control

See the Applications Information section for a description of how to use the UVLO/EN pin and/or the OVLO pin for remote shutdown and enable control of the LM5067.

Power Good Pin

The Power Good output indicator pin (PGD) is connected to the drain of an internal N-channel MOSFET. An external pull-up resistor is required at PGD to an appropriate voltage to indicate the status to downstream circuitry. The off-state voltage at the PGD pin must be more positive than VEE, and can be up to 80V above VEE with transient capability to 100V. PGD is switched high at the end of the turn-on sequence when the voltage from OUT to SENSE (the external MOSFET's V_{DS}) decreases below 1.23V. PGD switches low if the MOSFET's V_{DS} increases past 2.5V, if the system input voltage goes below the UVLO threshold or above the OVLO threshold, or if a fault is detected. The PGD output is high when the operating voltage ($V_{CC} - V_{EE}$) is less than 2V.

Application Information (Refer to Figure 1)

R_{IN} , C_{IN}

The LM5067 operating voltage is determined by an internal 13V shunt regulator which receives its current from the system voltage via R_{IN} . When the system voltage exceeds 13V, the LM5067 operating voltage ($V_{CC} - V_{EE}$) is between VEE and $VEE + 13V$. The remainder of the system voltage is dropped across the input resistor R_{IN} , which must be selected to pass at least 2 mA into the LM5067 at the minimum system voltage. The resistor's power rating must be selected based on the power dissipation at maximum system voltage, calculated from:

$$P_{RIN} = (V_{SYS(max)} - 13V)^2 / R_{IN}$$

CURRENT LIMIT, R_S

The LM5067 monitors the current in the external MOSFET (Q1) by measuring the voltage across the sense resistor

(R_S), connected from SENSE to VEE. The required resistor value is calculated from:

$$R_S = \frac{50 \text{ mV}}{I_{LIM}} \quad (1)$$

where I_{LIM} is the desired current limit threshold. When the voltage across R_S reaches 50 mV, the current limit circuit modulates the gate of Q1 to regulate the current at I_{LIM} . While the current limiting circuit is active, the fault timer is active as described in the Fault Timer & Restart section. For proper operation, R_S must be no larger than 100 m Ω .

While the maximum load current in normal operation can be used to determine the required power rating for resistor R_S , basing it on the current limit value provides a more reliable design since the circuit can operate near the current limit threshold continuously. The resistor's surge capability must also be considered since the circuit breaker threshold is approximately twice the current limit threshold. Connections from R_S to the LM5067 should be made using Kelvin techniques. In the suggested layout of Figure 7 the small pads at the upper corners of the sense resistor connect only to the sense resistor terminals, and not to the traces carrying the high current. With this technique, only the voltage across the sense resistor is applied to VEE and SENSE, eliminating the voltage drop across the high current solder connections.

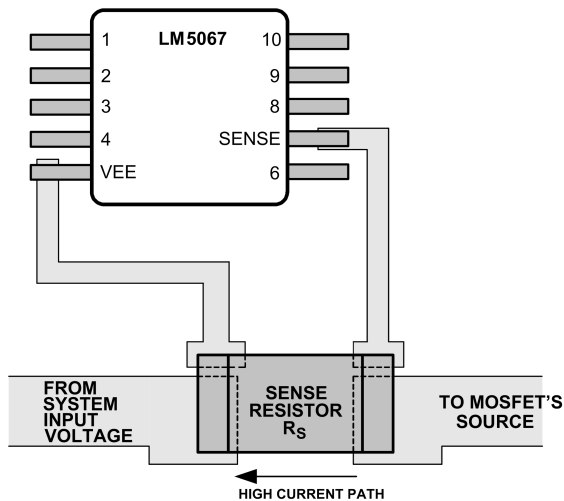

30030935

FIGURE 7. Sense Resistor Connections

POWER LIMIT THRESHOLD

The LM5067 determines the power dissipation in the external MOSFET (Q1) by monitoring the drain current (the current in R_S), and the V_{DS} of Q1 (OUT to SENSE pins). The resistor at the PWR pin (R_{PWR}) sets the maximum power dissipation for Q1, and is calculated from the following equation:

$$R_{PWR} = 1.42 \times 10^5 \times R_S \times P_{FET(LIM)} \quad (2)$$

where $P_{FET(LIM)}$ is the desired power limit threshold for Q1, and R_S is the current sense resistor described in the Current Limit section. For example, if R_S is 10 m Ω , and the desired power limit threshold is 60W, R_{PWR} calculates to 85.2 k Ω . If Q1's power dissipation reaches the power limit threshold, Q1's gate is modulated to control the load current, keeping Q1's power from exceeding the threshold. For proper operation of the power limiting feature, R_{PWR} must be ≤ 150 k Ω . While the power limiting circuit is active, the fault timer is ac-

tive as described in the Fault Timer & Restart section. Typically, power limit is reached during startup, or when the V_{DS} of Q1 increases due to a severe overload or short circuit.

The programmed maximum power dissipation should have a reasonable margin relative to the maximum power defined by the SOA chart if the LM5067-2 is used since the FET will be repeatedly stressed during fault restart cycles. The FET manufacturer should be consulted for guidelines. The PWR pin can be left open if the application does not require use of the power limit function.

TURN-ON TIME

The output turn-on time depends on whether the LM5067 operates in current limit only, or in both power limit and current limit, during turn-on.

A) Turn-on with current limit only: If the current limit threshold is less than the current defined by the power limit threshold at maximum V_{DS} the circuit operates only at the current limit threshold during turn-on. Referring to Figure 10a, as the drain current reaches I_{LIM} , the gate-to-source voltage is controlled at V_{GSL} to maintain the current at I_{LIM} . As the output voltage reaches its final value ($V_{DS} \approx 0V$) the drain current reduces to the value defined by the load, and the gate is charged to approximately 13V (V_{GATE}). The time for the OUT pin voltage to transition from zero volts to V_{SYS} is equal to:

$$t_{ON} = \frac{V_{SYS} \times C_L}{I_{LIM}}$$

where C_L is the load capacitance. For example, if $V_{SYS} = -48V$, $C_L = 1000 \mu F$, and $I_{LIM} = 1A$, t_{ON} calculates to 48 ms. The maximum instantaneous power dissipated in the MOSFET is 48W. This calculation assumes the time from t_1 to t_2 in Figure 10a is small compared to t_{ON} , and the load does not draw any current until after the output voltage has reached its final value, and PGD switches high (Figure 8).

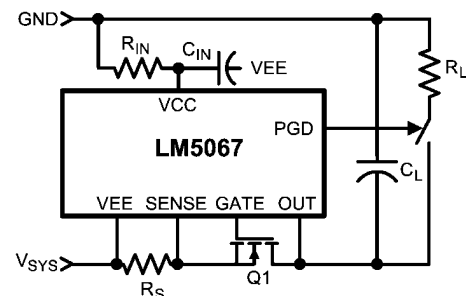

30030937

FIGURE 8. No Load Current During Turn-on

If the load draws current during the turn-on sequence (Figure 9), the turn-on time is longer than the above calculation, and is approximately equal to:

$$t_{ON} = -(R_L \times C_L) \times \ln \left[\frac{(I_{LIM} \times R_L) - V_{SYS}}{(I_{LIM} \times R_L)} \right]$$

where R_L is the load resistance and V_{SYS} is the absolute value of the system input voltage. **The Fault Timeout Period must be set longer than t_{ON} to prevent a fault shutdown before the turn-on sequence is complete.**

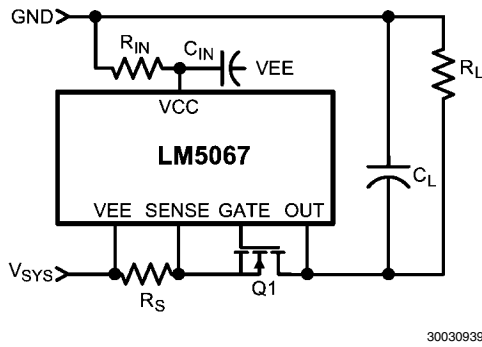

FIGURE 9. Load Draws Current During Turn-On

B) Turn-on with power limit and current limit: The power dissipation limit in Q1 ($P_{FET(LIM)}$) is defined by the resistor at the PWR pin, and the current sense resistor R_S . See the

Power Limit Threshold section. If the current limit threshold (I_{LIM}) is higher than the current defined by the power limit threshold at maximum V_{DS} ($P_{FET(LIM)}/V_{SYS}$) the circuit operates initially in power limit mode when the V_{DS} of Q1 is high, and then transitions to current limit mode as the current increases to I_{LIM} as V_{DS} decreases. See Figure 10b. Assuming the load (R_L) is not connected during turn-on, the time for the output voltage to reach its final value is approximately equal to:

$$t_{ON} = \frac{C_L \times V_{SYS}^2}{2 \times P_{FET(LIM)}} + \frac{C_L \times P_{FET(LIM)}}{2 \times I_{LIM}^2}$$

For example, if $V_{SYS} = -48V$, $C_L = 1000 \mu F$, $I_{LIM} = 1A$, and $P_{FET(LIM)} = 20W$, t_{ON} calculates to ≈ 68 ms, and the initial current level (I_P) is approximately 0.42A. **The Fault Timeout Period must be set longer than t_{ON} .**

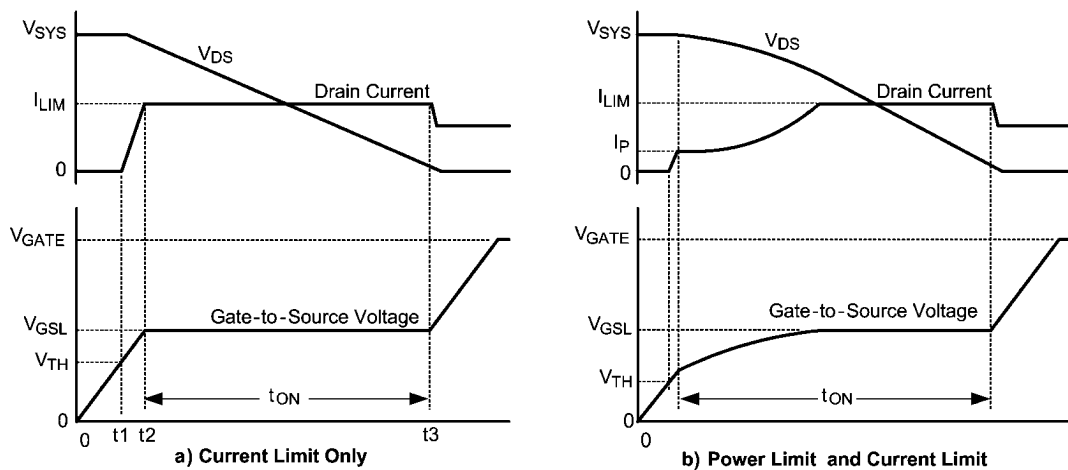

FIGURE 10. MOSFET Power Up Waveforms

MOSFET SELECTION

It is recommended that the external MOSFET (Q1) selection be based on the following criteria:

- The BV_{DSS} rating should be greater than the maximum system voltage (V_{SYS}), plus ringing and transients which can occur at V_{SYS} when the circuit card, or adjacent cards, are inserted or removed.
- The maximum continuous current rating should be based on the current limit threshold ($50 \text{ mV}/R_S$), not the maximum load current, since the circuit can operate near the current limit threshold continuously.
- The Pulsed Drain Current spec (I_{DM}) must be greater than the current threshold for the circuit breaker function ($100 \text{ mV}/R_S$).
- The SOA (Safe Operating Area) chart of the device, and the thermal properties, should be used to determine the maximum power dissipation threshold set by the R_{PWR} resistor. The programmed maximum power dissipation should have a reasonable margin from the maximum power defined by the FET's SOA chart if the LM5067-2 is used since the FET will be repeatedly stressed during fault restart cycles. The FET manufacturer should be consulted for guidelines.
- $R_{DS(on)}$ should be sufficiently low that the power dissipation at maximum load current ($I_{L(max)}^2 \times R_{DS(on)}$) does not raise its junction temperature above the manufacturer's recommendation.

If the device chosen for Q1 has a maximum V_{GS} rating less than 13V, an external zener diode must be added from its gate to source, with the zener voltage less than the maximum V_{GS} rating. The zener diode's forward current rating must be at least 110 mA to conduct the GATE pull-down current during startup and in the circuit breaker mode.

TIMER CAPACITOR, C_T

The TIMER pin capacitor (C_T) sets the timing for the insertion time delay, fault timeout period, and restart timing of the LM5067-2.

A) Insertion Delay - Upon applying the system voltage (V_{SYS}) to the circuit, the external MOSFET (Q1) is held off during the insertion time (t_1 in Figure 3) to allow ringing and transients at V_{SYS} to settle. Since each backplane's response to a circuit card plug-in is unique, the worst case settling time must be determined for each application. The insertion time starts when the operating voltage (V_{CC} - V_{EE}) reaches the POR_{IT} threshold, at which time the internal $6 \mu\text{A}$ current source charges C_T from 0V to 4.0V. The required capacitor value is calculated from:

$$C_T = \frac{t_1 \times 6 \mu\text{A}}{4\text{V}} = t_1 \times 1.5 \times 10^{-6}$$

where t_1 is the desired insertion delay. For example, if the desired insertion delay is 250 ms, C_T calculates to $0.38 \mu\text{F}$. At the end of the insertion delay, C_T is quickly discharged by a 1.5 mA current sink.

B) Fault Timeout Period - During turn-on of the output voltage, or upon detection of a fault condition where the current limit and/or power limit circuits regulate the current through Q1, C_T is charged by the fault timer current source ($85 \mu\text{A}$). The Fault Timeout Period is the time required for the TIMER pin voltage to reach 4.0V above VEE, at which time Q1 is switched off. The required capacitor value for the desired Fault Timeout Period t_{FAULT} is calculated from:

$$C_T = \frac{t_{FAULT} \times 85 \mu\text{A}}{4\text{V}} = t_{FAULT} \times 2.13 \times 10^{-5} \quad (3)$$

For example, if the desired Fault Timeout Period is 16 ms, C_T calculates to $0.34 \mu\text{F}$. After a fault timeout, if the LM5067-1 is in use, C_T must be allowed to discharge to $<0.3\text{V}$ by the $2.5 \mu\text{A}$ current sink, after which a power up sequence can be initiated by external circuitry. See the Fault Timer and Restart section and Figure 5. If the LM5067-2 is in use, after the Fault Timeout Period expires a restart sequence begins as described below (Restart Timing).

Since the LM5067 normally operates in power limit and/or current limit during a power up sequence, the Fault Timeout Period **MUST** be longer than the time required for the output voltage to reach its final value. See the Turn-on Time section.

C) Restart Timing If the LM5067-2 is in use, after the Fault Timeout Period described above, C_T is discharged by the $2.5 \mu\text{A}$ current sink to 1.25V. The TIMER pin then cycles through seven additional charge/discharge cycles between 1.25V and 4.0V as shown in Figure 6. The restart time ends when the TIMER pin voltage reaches 0.3V during the final high-to-low ramp. The restart time, after the Fault Timeout Period, is equal to:

$$t_{RESTART} = C_T \times \left[\frac{7 \times 2.75\text{V}}{2.5 \mu\text{A}} + \frac{7 \times 2.75\text{V}}{85 \mu\text{A}} + \frac{3.7\text{V}}{2.5 \mu\text{A}} \right]$$

$$= C_T \times 9.4 \times 10^6$$

For example, if $C_T = 0.33 \mu\text{F}$, $t_{RESTART} = 3.1$ seconds. At the end of the restart time, Q1 is switched on. If the fault is still present, the fault timeout and restart sequence repeats. The on-time duty cycle of Q1 is approximately 0.5% in this mode.

UVLO, OVLO

By programming the UVLO and OVLO thresholds the LM5067 enables the series pass device (Q1) when the input supply voltage (V_{SYS}) is within the desired operational range. If V_{SYS} is below the UVLO threshold, or above the OVLO threshold, Q1 is switched off, denying power to the load. Hysteresis is provided for each threshold.

Note: All voltages are with respect to Vee in the discussions below. Use absolute values in the equations.

Option A: The configuration shown in Figure 11 requires three resistors (R1-R3) to set the thresholds.

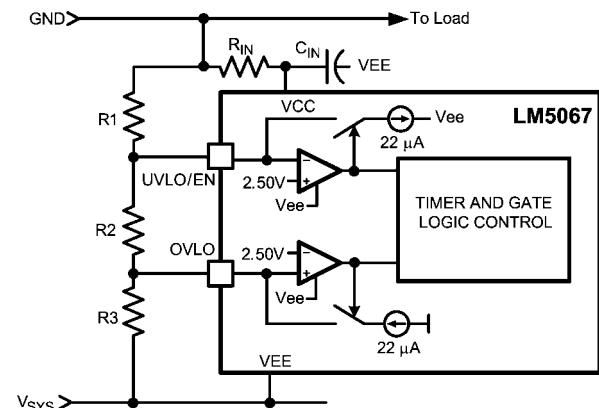

30030946

FIGURE 11. UVLO and OVLO Thresholds Set By R1-R3

The procedure to calculate the resistor values is as follows:

- Determine the upper UVLO threshold (V_{UVH}) to enable Q1, and the lower UVLO threshold (V_{UVL}) to disable Q1.
- Determine the upper OVLO threshold (V_{OVH}) to disable Q1.
- The lower OVLO threshold (V_{OVL}), to enable Q1, cannot be chosen in advance in this case, but is determined after the values for R1-R3 are determined. If V_{OVL} must be accurately defined in addition to the other three thresholds, see Option B below.

The resistors are calculated as follows:

$$R1 = \frac{V_{UVH} - V_{UVL}}{22 \mu A} = \frac{V_{UV(HYS)}}{22 \mu A}$$

$$R3 = \frac{2.5V \times R1 \times V_{UVL}}{V_{OVH} \times (V_{UVL} - 2.5V)}$$

$$R2 = \frac{2.5V \times R1}{V_{UVL} - 2.5V} - R3$$

The lower OVLO threshold is calculated from:

$$V_{OVL} = \left[(R1 + R2) \times \frac{(2.5V) - 22 \mu A}{R3} \right] + 2.5V$$

As an example, assume the application requires the following thresholds: $V_{UVH} = -36V$, $V_{UVL} = -32V$, $V_{OVH} = -60V$.

$$R1 = \frac{36V - 32V}{22 \mu A} = \frac{4V}{22 \mu A} = 182 \text{ k}\Omega$$

$$R3 = \frac{2.5V \times 182 \text{ k}\Omega \times 32V}{60V \times (32V - 2.5V)} = 8.23 \text{ k}\Omega$$

$$R2 = \frac{2.5V \times 182 \text{ k}\Omega}{(32V - 2.5V)} - 8.23 \text{ k}\Omega = 7.19 \text{ k}\Omega$$

The lower OVLO threshold calculates to -55.8V, and the OVLO hysteresis is 4.2V. Note that the OVLO hysteresis is always slightly greater than the UVLO hysteresis in this configuration.

When the R1-R3 resistor values are known, the threshold voltages and hysteresis are calculated from the following:

$$V_{UVH} = 2.5V + \left[R1 \times (22 \mu A + \frac{2.5V}{(R2 + R3)}) \right]$$

$$V_{UVL} = \frac{2.5V \times (R1 + R2 + R3)}{R2 + R3}$$

$$V_{UV(HYS)} = R1 \times 22 \mu A$$

$$V_{OVH} = \frac{2.5V \times (R1 + R2 + R3)}{R3}$$

$$V_{OVL} = \left[(R1 + R2) \times \frac{(2.5V) - 22 \mu A}{R3} \right] + 2.5V$$

$$V_{OV(HYS)} = (R1 + R2) \times 22 \mu A$$

Note: Ensure the voltages at the UVLO and OVLO pins do not exceed the Absolute Maximum ratings for those pins when the system voltage is at maximum.

Option B: If all four thresholds must be accurately defined, the configuration in Figure 12 can be used.

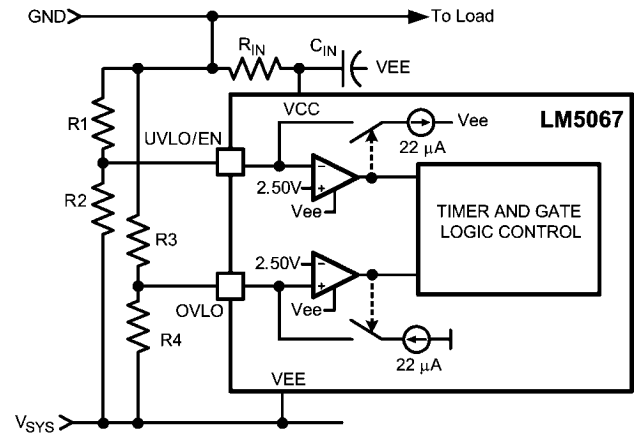

FIGURE 12. Programming the Four Thresholds

The four resistor values are calculated as follows:

- Determine the upper UVLO threshold (V_{UVH}) to enable Q1, and the lower UVLO threshold (V_{UVL}) to disable Q1.

$$R1 = \frac{V_{UVH} - V_{UVL}}{22 \mu A} = \frac{V_{UV(HYS)}}{22 \mu A}$$

$$R2 = \frac{2.5V \times R1}{(V_{UVL} - 2.5V)}$$

- Determine the upper OVLO threshold (V_{OVH}) to disable Q1, and the lower OVLO threshold (V_{OVL}) to enable Q1.

$$R3 = \frac{V_{OVH} - V_{OVL}}{22 \mu A} = \frac{V_{OV(HYS)}}{22 \mu A}$$

$$R4 = \frac{2.5V \times R3}{(V_{OVH} - 2.5V)}$$

As an example, assume the application requires the following thresholds: $V_{UVH} = -22V$, $V_{UVL} = -17V$, $V_{OVH} = -60V$, and $V_{OVL} = -58V$. Therefore $V_{UV(HYS)} = 5V$, and $V_{OV(HYS)} = 2V$. The resistor values are:

$$R1 = 227 \text{ k}\Omega, R2 = 39.1 \text{ k}\Omega$$

$$R3 = 90.9 \text{ k}\Omega, R4 = 3.95 \text{ k}\Omega$$

Where the R1-R4 resistor values are known, the threshold voltages and hysteresis are calculated from the following:

$$V_{UVH} = 2.5V + [R1 \times \frac{(2.5V + 22 \mu A)}{R2}]$$

$$V_{UVL} = \frac{2.5V \times (R1 + R2)}{R2}$$

$$V_{UV(HYS)} = R1 \times 22 \mu A$$

$$V_{OVH} = \frac{2.5V \times (R3 + R4)}{R4}$$

$$V_{OVL} = 2.5V + [R3 \times \frac{(2.5V - 22 \mu A)}{R4}]$$

$$V_{OV(HYS)} = R3 \times 22 \mu A$$

Note: Ensure the voltages at the UVLO and OVLO pins do not exceed the Absolute Maximum ratings for those pins when the system voltage is at maximum.

Option C: The minimum UVLO level is obtained by connecting the UVLO pin to VCC as shown in Figure 13. Q1 is switched on when the operating voltage reaches the POR_{EN} threshold ($\approx 8.4V$). The OVLO thresholds are set by R3 and R4 using the procedure in Option B.

Note: Ensure the voltage at the OVLO pin does not exceed the Absolute Maximum ratings for that pin when the system voltage is at maximum.

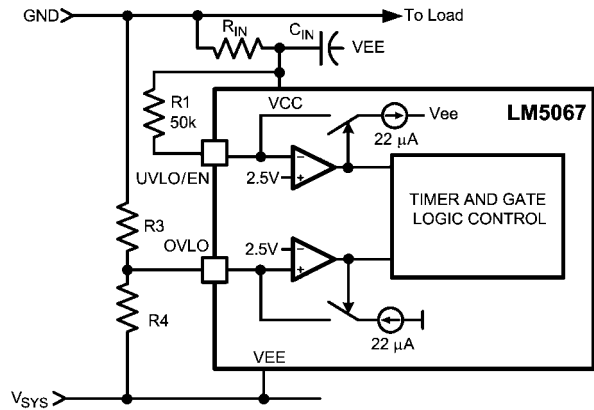

30030955

FIGURE 13. UVLO = POR_{EN}

Option D: The OVLO function can be disabled by connecting the OVLO pin to VEE. The UVLO thresholds are set as described in Option B or Option C.

SHUTDOWN / ENABLE CONTROL

Figure 14a shows how to use the UVLO/EN pin for remote shutdown and enable control. Taking the UVLO/EN pin below its 2.5V threshold (with respect to VEE) shuts off the load current. Upon releasing the UVLO/EN pin the LM5067 switches on the load current with in-rush current and power limiting. In Figure 14b the OVLO pin is used for remote shutdown and enable control. When the external transistor is off, the OVLO pin is above its 2.5V threshold (with respect to VEE) and the load current is shut off. Turning on the external transistor allows the LM5067 to switch on the load current with in-rush current and power limiting.

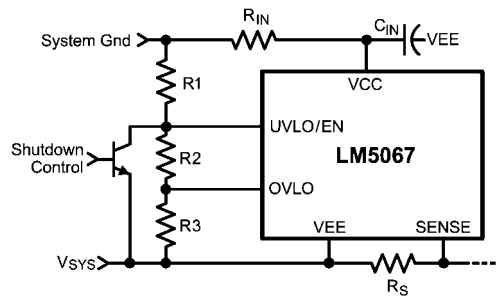

30030956

a) Shutdown/Enable Using the UVLO/EN Pin

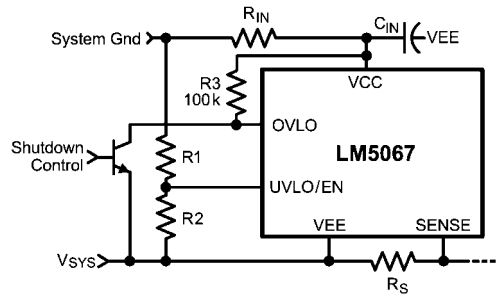

30030957

b) Shutdown/Enable Using the OVLO Pin

FIGURE 14. Shutdown/Enable

POWER GOOD PIN

During initial power up, the Power Good pin (PGD) is high until the operating voltage ($V_{CC} - V_{EE}$) increases above $\approx 2V$. PGD then switches low, remaining low as the system voltage and the operating voltage increase. After Q1 is switched on, when the voltage at the OUT pin is within 1.23V of the SENSE pin (Q1's $V_{DS} < 1.23V$), PGD switches high indicating the output voltage is at, or nearly at, its final value. Any of the following situations will cause PGD to switch low within $\approx 10 \mu s$:

- The V_{DS} of Q1 increases above 2.5V.
- The system input voltage decreases below the UVLO level.
- The system input voltage increase above the OVLO level.
- The TIMER pin increases to 4V due to a fault condition.

A pull-up resistor is required at PGD as shown in Figure 15. The pull-up voltage (V_{PGD}) can be as high as 80V above VEE, with transient capability to 100V, and can be higher or lower than the system ground.

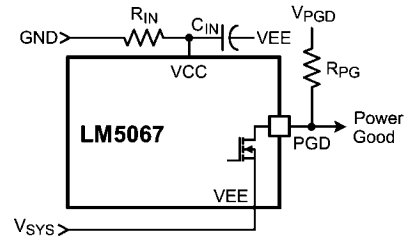

30030958

FIGURE 15. Power Good Output

If a delay is required at PGD, suggested circuits are shown in Figure 16. In Figure 16a, capacitor C_{PG} adds delay to the rising edge, but not to the falling edge. In Figure 16b, the rising edge is delayed by $R_{PG1} + R_{PG2}$ and C_{PG} , while the falling edge is delayed a lesser amount by R_{PG2} and C_{PG} . Adding a diode across R_{PG2} (Figure 16c) allows for equal delays at the two edges, or a short delay at the rising edge and a long delay at the falling edge.

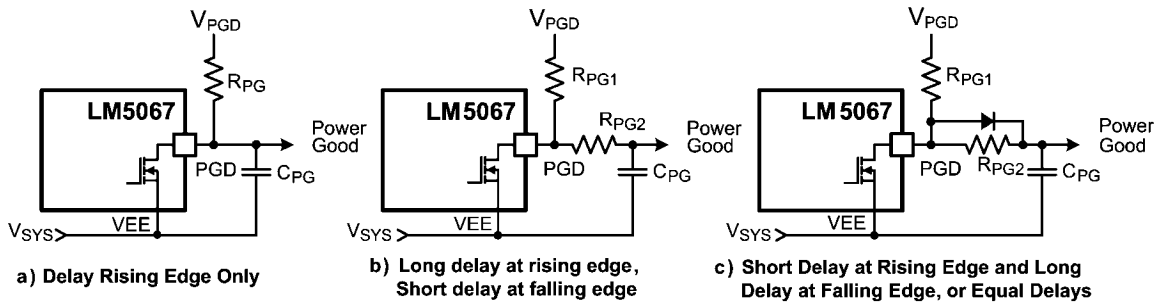

30030959

FIGURE 16. Adding Delay to the Power Good Output Pin

Design-in Procedure

The recommended design-in procedure for the LM5067 is as follows:

- Determine the minimum and maximum system voltages (V_{EE}). Select the input resistor (R_{IN}) to provide at least 2 mA into the VCC pin at the minimum system voltage. The resistor's power rating must be suitable for its power dissipation at maximum system voltage ($(V_{SYS} - 13V)^2 / R_{IN}$).
- Determine the current limit threshold (I_{LIM}). This threshold must be higher than the normal maximum load current, allowing for tolerances in the current sense resistor value and the LM5067 Current Limit threshold voltage. Use equation 1 to determine the value for R_S .
- Determine the maximum allowable power dissipation for the series pass FET (Q1), using the device's SOA information. Use equation 2 to determine the value for R_{PWR} .
- Determine the value for the timing capacitor at the TIMER pin (C_T) using equation 3. **The fault timeout period (t_{FAULT}) must be longer than the circuit's turn-on-time.** The turn-on time can be estimated using the equations in the Turn-on Time section of this data sheet, but should be verified experimentally. Allow for tolerances in the values of the external capacitors, sense resistor, and the LM5067 Electrical Characteristics for the TIMER pin, current limit and power limit. Review the resulting insertion time, and the restart timing if the LM5067-2 is used.
- Choose option A, B, C, or D from the UVLO, OVLO section of the Application Information for setting the UVLO and OVLO thresholds and hysteresis. Use the procedure in the appropriate option to determine the resistor values at the UVLO and OVLO pins.
- Choose the appropriate voltage, and pull-up resistor, for the Power Good output.

Thermal Considerations

The LM5067 should be operated so that its junction temperature does not exceed 125°C. The junction temperature is equal to:

$$T_J = T_A + (R_{\theta JA} \times P_D)$$

where T_A is the ambient temperature, and $R_{\theta JA}$ is the thermal resistance of the LM5067. P_D is the power dissipated within the LM5067, calculated from:

$$P_D = 13V \times I_{CC}$$

where I_{CC} is the current into the VCC pin (the current through the R_{IN} resistor). Values for $R_{\theta JA}$ and $R_{\theta JC}$ are in the table of Electrical Characteristics.

System Considerations

A) Continued proper operation of the LM5067 hot swap circuit requires capacitance be present on the supply side of the

connector into which the hot swap circuit is plugged in, as depicted in Figure 2. The capacitor in the “Live Backplane” section is necessary to absorb the transient generated whenever the hot swap circuit shuts off the load current. If the capacitance is not present, inductance in the supply lines will generate a voltage transient at shut-off which can exceed the absolute maximum rating of the LM5067, resulting in its destruction.

B) If the load powered via the LM5067 hot swap circuit has inductive characteristics, a diode is required across the LM5067’s output to provide a recirculating path for the load’s current. Adding the diode prevents possible damage to the LM5067 as the OUT pin will be taken above ground by the inductive load at shutoff. See [Figure 18](#).

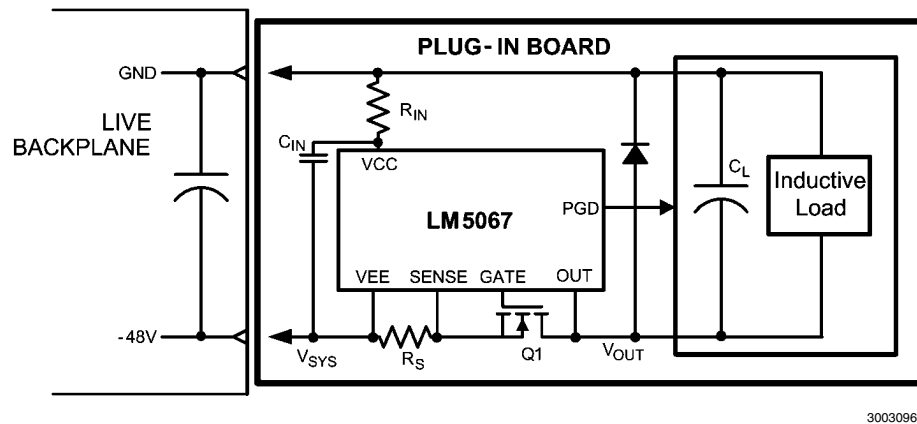
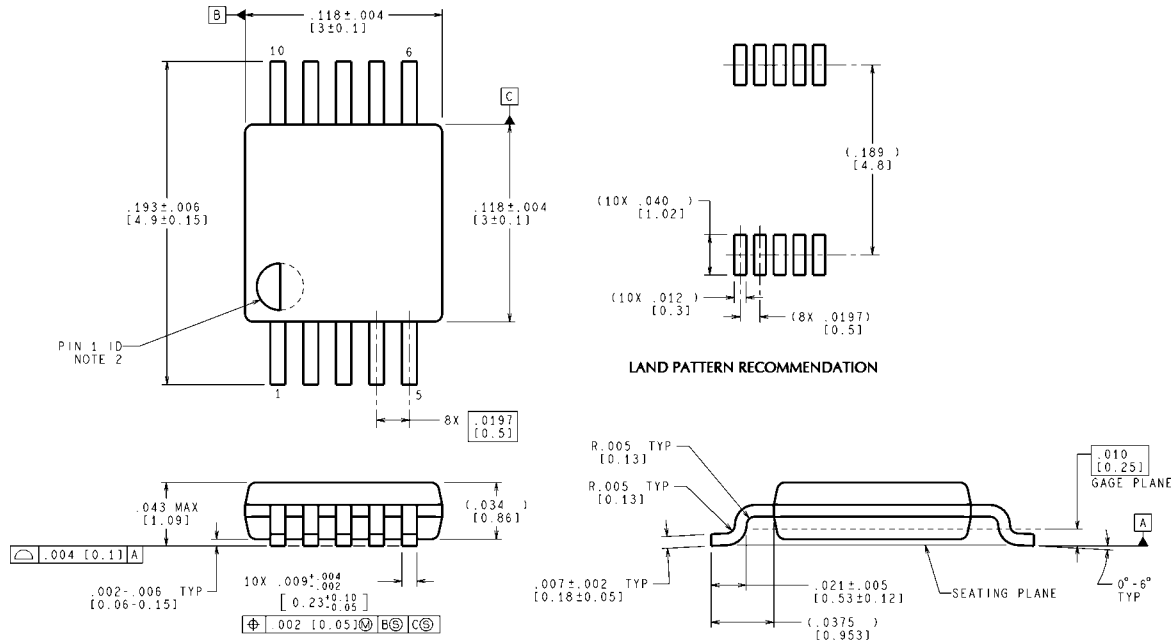

FIGURE 18. Output Diode Required for Inductive Loads

Physical Dimensions inches (millimeters) unless otherwise noted



CONTROLLING DIMENSION IS INCH
 VALUES IN [] ARE MILLIMETERS
 DIMENSIONS IN () FOR REFERENCE ONLY

NS Package Number MUB10A

MUB10A (Rev B)

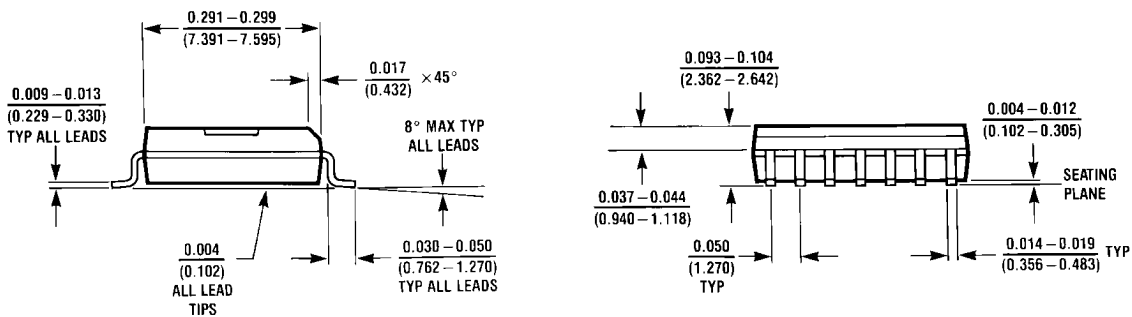
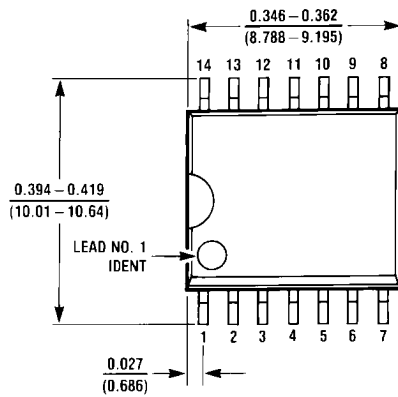

NS Package Number M14B

M14B (REV D)

Notes

For more National Semiconductor product information and proven design tools, visit the following Web sites at:

Products		Design Support	
Amplifiers	www.national.com/amplifiers	WEBENCH® Tools	www.national.com/webench
Audio	www.national.com/audio	App Notes	www.national.com/appnotes
Clock and Timing	www.national.com/timing	Reference Designs	www.national.com/refdesigns
Data Converters	www.national.com/adc	Samples	www.national.com/samples
Interface	www.national.com/interface	Eval Boards	www.national.com/evalboards
LVDS	www.national.com/lvds	Packaging	www.national.com/packaging
Power Management	www.national.com/power	Green Compliance	www.national.com/quality/green
Switching Regulators	www.national.com/switchers	Distributors	www.national.com/contacts
LDOs	www.national.com/ldo	Quality and Reliability	www.national.com/quality
LED Lighting	www.national.com/led	Feedback/Support	www.national.com/feedback
Voltage Reference	www.national.com/vref	Design Made Easy	www.national.com/easy
PowerWise® Solutions	www.national.com/powerwise	Solutions	www.national.com/solutions
Serial Digital Interface (SDI)	www.national.com/sdi	Mil/Aero	www.national.com/milaero
Temperature Sensors	www.national.com/tempensors	SolarMagic™	www.national.com/solarmagic
Wireless (PLL/VCO)	www.national.com/wireless	PowerWise® Design University	www.national.com/training

THE CONTENTS OF THIS DOCUMENT ARE PROVIDED IN CONNECTION WITH NATIONAL SEMICONDUCTOR CORPORATION ("NATIONAL") PRODUCTS. NATIONAL MAKES NO REPRESENTATIONS OR WARRANTIES WITH RESPECT TO THE ACCURACY OR COMPLETENESS OF THE CONTENTS OF THIS PUBLICATION AND RESERVES THE RIGHT TO MAKE CHANGES TO SPECIFICATIONS AND PRODUCT DESCRIPTIONS AT ANY TIME WITHOUT NOTICE. NO LICENSE, WHETHER EXPRESS, IMPLIED, ARISING BY ESTOPPEL OR OTHERWISE, TO ANY INTELLECTUAL PROPERTY RIGHTS IS GRANTED BY THIS DOCUMENT.

TESTING AND OTHER QUALITY CONTROLS ARE USED TO THE EXTENT NATIONAL DEEMS NECESSARY TO SUPPORT NATIONAL'S PRODUCT WARRANTY. EXCEPT WHERE MANDATED BY GOVERNMENT REQUIREMENTS, TESTING OF ALL PARAMETERS OF EACH PRODUCT IS NOT NECESSARILY PERFORMED. NATIONAL ASSUMES NO LIABILITY FOR APPLICATIONS ASSISTANCE OR BUYER PRODUCT DESIGN. BUYERS ARE RESPONSIBLE FOR THEIR PRODUCTS AND APPLICATIONS USING NATIONAL COMPONENTS. PRIOR TO USING OR DISTRIBUTING ANY PRODUCTS THAT INCLUDE NATIONAL COMPONENTS, BUYERS SHOULD PROVIDE ADEQUATE DESIGN, TESTING AND OPERATING SAFEGUARDS.

EXCEPT AS PROVIDED IN NATIONAL'S TERMS AND CONDITIONS OF SALE FOR SUCH PRODUCTS, NATIONAL ASSUMES NO LIABILITY WHATSOEVER, AND NATIONAL DISCLAIMS ANY EXPRESS OR IMPLIED WARRANTY RELATING TO THE SALE AND/OR USE OF NATIONAL PRODUCTS INCLUDING LIABILITY OR WARRANTIES RELATING TO FITNESS FOR A PARTICULAR PURPOSE, MERCHANTABILITY, OR INFRINGEMENT OF ANY PATENT, COPYRIGHT OR OTHER INTELLECTUAL PROPERTY RIGHT.

LIFE SUPPORT POLICY

NATIONAL'S PRODUCTS ARE NOT AUTHORIZED FOR USE AS CRITICAL COMPONENTS IN LIFE SUPPORT DEVICES OR SYSTEMS WITHOUT THE EXPRESS PRIOR WRITTEN APPROVAL OF THE CHIEF EXECUTIVE OFFICER AND GENERAL COUNSEL OF NATIONAL SEMICONDUCTOR CORPORATION. As used herein:

Life support devices or systems are devices which (a) are intended for surgical implant into the body, or (b) support or sustain life and whose failure to perform when properly used in accordance with instructions for use provided in the labeling can be reasonably expected to result in a significant injury to the user. A critical component is any component in a life support device or system whose failure to perform can be reasonably expected to cause the failure of the life support device or system or to affect its safety or effectiveness.

National Semiconductor and the National Semiconductor logo are registered trademarks of National Semiconductor Corporation. All other brand or product names may be trademarks or registered trademarks of their respective holders.

Copyright© 2009 National Semiconductor Corporation

For the most current product information visit us at www.national.com



**National Semiconductor
Americas Technical
Support Center**
Email: support@nsc.com
Tel: 1-800-272-9959

**National Semiconductor Europe
Technical Support Center**
Email: europe.support@nsc.com

**National Semiconductor Asia
Pacific Technical Support Center**
Email: ap.support@nsc.com

**National Semiconductor Japan
Technical Support Center**
Email: jpn.feedback@nsc.com

IMPORTANT NOTICE

Texas Instruments Incorporated and its subsidiaries (TI) reserve the right to make corrections, modifications, enhancements, improvements, and other changes to its products and services at any time and to discontinue any product or service without notice. Customers should obtain the latest relevant information before placing orders and should verify that such information is current and complete. All products are sold subject to TI's terms and conditions of sale supplied at the time of order acknowledgment.

TI warrants performance of its hardware products to the specifications applicable at the time of sale in accordance with TI's standard warranty. Testing and other quality control techniques are used to the extent TI deems necessary to support this warranty. Except where mandated by government requirements, testing of all parameters of each product is not necessarily performed.

TI assumes no liability for applications assistance or customer product design. Customers are responsible for their products and applications using TI components. To minimize the risks associated with customer products and applications, customers should provide adequate design and operating safeguards.

TI does not warrant or represent that any license, either express or implied, is granted under any TI patent right, copyright, mask work right, or other TI intellectual property right relating to any combination, machine, or process in which TI products or services are used. Information published by TI regarding third-party products or services does not constitute a license from TI to use such products or services or a warranty or endorsement thereof. Use of such information may require a license from a third party under the patents or other intellectual property of the third party, or a license from TI under the patents or other intellectual property of TI.

Reproduction of TI information in TI data books or data sheets is permissible only if reproduction is without alteration and is accompanied by all associated warranties, conditions, limitations, and notices. Reproduction of this information with alteration is an unfair and deceptive business practice. TI is not responsible or liable for such altered documentation. Information of third parties may be subject to additional restrictions.

Resale of TI products or services with statements different from or beyond the parameters stated by TI for that product or service voids all express and any implied warranties for the associated TI product or service and is an unfair and deceptive business practice. TI is not responsible or liable for any such statements.

TI products are not authorized for use in safety-critical applications (such as life support) where a failure of the TI product would reasonably be expected to cause severe personal injury or death, unless officers of the parties have executed an agreement specifically governing such use. Buyers represent that they have all necessary expertise in the safety and regulatory ramifications of their applications, and acknowledge and agree that they are solely responsible for all legal, regulatory and safety-related requirements concerning their products and any use of TI products in such safety-critical applications, notwithstanding any applications-related information or support that may be provided by TI. Further, Buyers must fully indemnify TI and its representatives against any damages arising out of the use of TI products in such safety-critical applications.

TI products are neither designed nor intended for use in military/aerospace applications or environments unless the TI products are specifically designated by TI as military-grade or "enhanced plastic." Only products designated by TI as military-grade meet military specifications. Buyers acknowledge and agree that any such use of TI products which TI has not designated as military-grade is solely at the Buyer's risk, and that they are solely responsible for compliance with all legal and regulatory requirements in connection with such use.

TI products are neither designed nor intended for use in automotive applications or environments unless the specific TI products are designated by TI as compliant with ISO/TS 16949 requirements. Buyers acknowledge and agree that, if they use any non-designated products in automotive applications, TI will not be responsible for any failure to meet such requirements.

Following are URLs where you can obtain information on other Texas Instruments products and application solutions:

Products

Audio	www.ti.com/audio
Amplifiers	amplifier.ti.com
Data Converters	dataconverter.ti.com
DLP® Products	www.dlp.com
DSP	dsp.ti.com
Clocks and Timers	www.ti.com/clocks
Interface	interface.ti.com
Logic	logic.ti.com
Power Mgmt	power.ti.com
Microcontrollers	microcontroller.ti.com
RFID	www.ti-rfid.com
OMAP Mobile Processors	www.ti.com/omap
Wireless Connectivity	www.ti.com/wirelessconnectivity

Applications

Communications and Telecom	www.ti.com/communications
Computers and Peripherals	www.ti.com/computers
Consumer Electronics	www.ti.com/consumer-apps
Energy and Lighting	www.ti.com/energy
Industrial	www.ti.com/industrial
Medical	www.ti.com/medical
Security	www.ti.com/security
Space, Avionics and Defense	www.ti.com/space-avionics-defense
Transportation and Automotive	www.ti.com/automotive
Video and Imaging	www.ti.com/video

TI E2E Community Home Page

e2e.ti.com

Mailing Address: Texas Instruments, Post Office Box 655303, Dallas, Texas 75265
Copyright © 2011, Texas Instruments Incorporated